



**TYPE : TC-311FF (PN16)**

**FEATURES**

- FACE TO FACE DIMENSIONS : DIN3202 F1
- END FLANGE DIMENSIONS : PN16 / PN40 DIN2633
- DESIGN : ANSI B16.34
- ½" – 2" PN40, 2½" – 4" PN16
- TEST : API 598
- LEVER OPERATED
- MATERIAL :

CARBON STEEL    WCB/1.0619  
 STAINLESS STEEL    304/1.4308  
 STAINLESS STEEL    316/1.4408

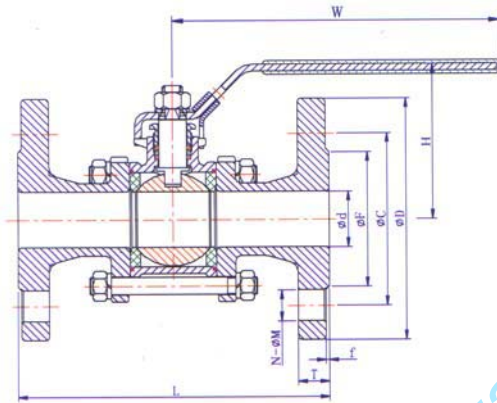

**MATERIALS LIST**

PART NAME	MATERIAL
BODY	WCB, CF8, CF8M
CAP	WCB, CF8, CF8M
BALL	SS304, SS316
STEM	SS316
SEAT	PTFE
BODY SEAL	PTFE
THRUST WASHER	PTFE
STEM PACKING	PTFE
BOLT	SS304
HEX NUT	SS304
BOLT WASHER	SS304
GLAND NUT	SS304
STEM WASHER	SS304
STEM NUT	SS304
HANDLE	SS304
PLASTIC COVER	PLASTIC
LOCKING DEVICE	SS304

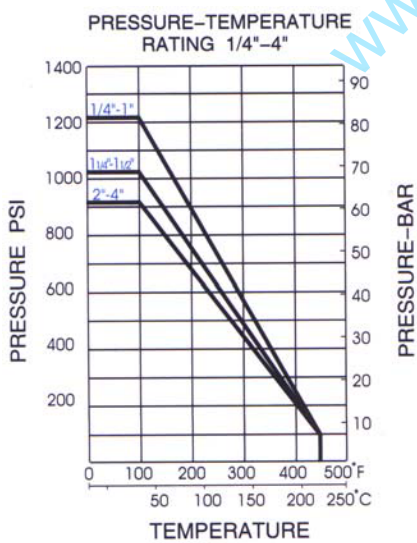

**DIMENSIONS**

SIZE	d	D	C	F	T	f	M	N	L	H	W
½"	15	95	65	45	16	2	14	4	130	64.9	123.3
¾"	20	105	75	58	18	2	14	4	150	80.3	133
1"	25	115	85	68	18	2	14	4	160	84.1	133
1¼"	32	140	100	78	18	2	18	4	180	91.7	190
1½"	40	150	110	88	18	3	18	4	200	98	190
2"	50	165	125	102	20	3	18	4	230	102.6	190
2½"	65	185	145	122	18	3	18	4	290	143	264
3"	80	200	160	138	20	3	18	8	310	154	264
4"	100	220	180	158	20	3	18	8	350	183	268